

RELEVANT PRODUCTS OF CHAIN REPAIR SERVICE



BS3506
Chain Link Pliers



BS1164
Drive Chain Tension Puller



BS0353
Chain Adjustable C Hook
Wrench



BS3500
Chain Extractor

APO TOOL INTERNATIONAL LTD.
No.38 Ping An St, Changhua, Taiwan 50055
T: +886 4 7514888 / F: +886 4 7524888
Website : www.bikeservice.com.tw
E-mail : service@bikeservice.com.tw

Represent.



BS3510 PROFESSIONAL CHAIN REPAIRING MASTER SET Instructions



RIVETING MASTER LINK HOLLOW PINS

Assembly of the Tool

01. Reassemble the tool to rivet or mushroom the hollow pins. **(Fig L)**
02. Thread the Center Screw into the Body of the tool.
03. Assemble the Rivet Tip into the Center Screw end thread and the Anvil in the thread of the tool.
04. Using a 21 mm spanner firstly tighten the Center Screw checking that the link is correctly aligned.
05. Tighten the Forcing Screw either via the T-bar or 21 mm spanner ensuring the tool Rivet is centered on the Master Link Pin. **(Fig J)**
06. Remove and repeat this procedure on the second Master Link Pin.
07. Check that the Master link Pins are correctly Riveted as per the chain manufacturers recommendation. **(Fig K)**
08. Do not over tighten as this can cause damage to the Master Link hollow pin or the Tool riveting pin.



IMPORTANT

Check the line of sight to ensure that the chain is aligned straight. Tension the chain and align the wheel to the manufacturers specification.

Please pay attention that if the chain pin and side link are positioned correctly when repeat using Master Chain Link. If they are in the wrong position, please repeat the **Breaking Chain Operation 4**. using Push Pin to fix the chain pin at the point of side link. Please check the figure.

(Fig H) Refer to the chain manufacturer's specifications for distance of chain pin protrusion, and direction and installation of master link clips.

All chains are different, and **BikeService** cannot provide the exact specification for your chain.

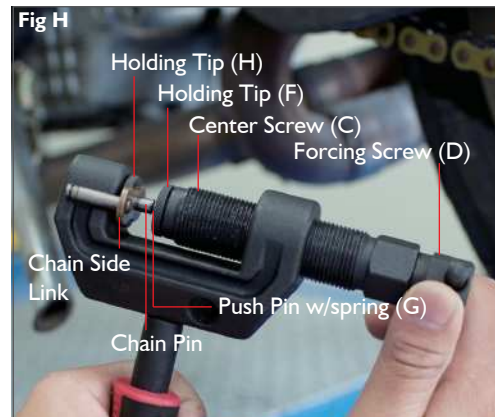

The **BikeService BS3510 Chain Repairing Master Tool** is designed to break chains up to chain size #632 and press the hollow link pins and plates of the Master Link on chains up to #632. Please read instructions thoroughly prior to use.

The Tool is designed for hand use (tightened by hand) utilizing the T-Bar or 3/8" Square and 19mm with 21mm spanner. The use of Power Tools or extension bars for extra leverage may cause damage to the tool and should be avoided.

Collocating **BikeService** products **BS3506 Chain Link Clip Pliers** and **BS1164 Drive Chain Tension Puller**, makes it easier and more convenient to remove and install motorcycle chain.

COMPONENT IDENTIFICATION

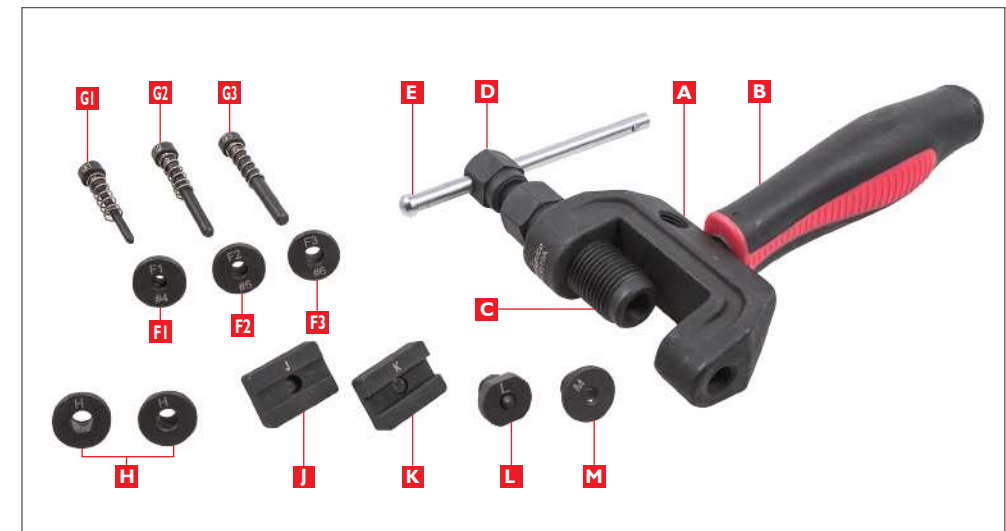

Contents:

- | | | |
|------------------------|--|---------------------------------|
| A Body | F1 Small Holding Tip for #4 chains | H Holding Tip x 2 pieces |
| B Handle | F2 Medium Holding Tip for #5 chains | J Shallow Press Block |
| C Center Screw | F3 Large Holding Tip for #6 chains | K Deep Press Block |
| D Forcing Screw | G1 Small Push Pin w/spring for #4 chains | L Rivet Tip |
| E T-Bar | G2 Medium Push Pin w/spring for #5 chains | M Anvil |
| | G3 Large Push Pin w/spring for #6 chains | |

PRODUCT FEATURE(PATENT PENDING)

This special Forcing Screw adopts a multifunctional driving mode (T bar / 19mm & 21mm Hex Wrench or Socket / 3/8" Square Driver) › which makes the removal and installation process more convenient and easier in any working environment without having tool specification limits. You can easily find one of the above tools to do the job.



Use with T Bar to drive.

Use with 3/8" Square Driver tool.

Use with 19mm & 21mm Hex Wrench or Sockets.

This special Ball Tip design Forcing Screw makes the operation more convenient and effective. This unique application helps to reduce the direct friction with Push Pin, and avoids the rotation of Push Pin which will make Push Pin misalign from Chain Pin during chain-breaking process.

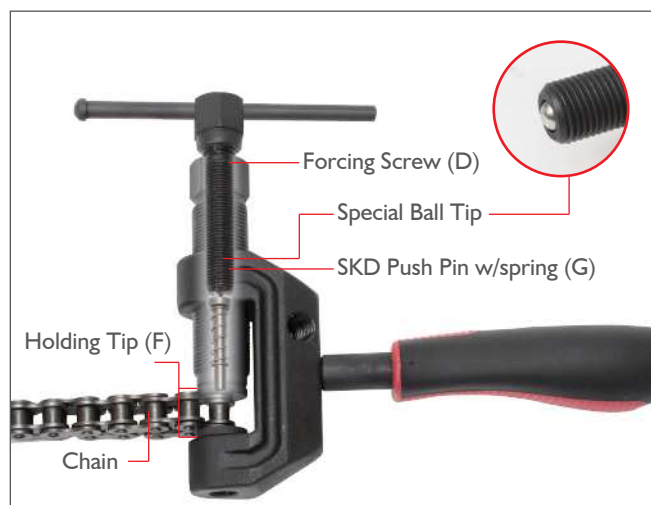

(Fig E) Chain assembly and riveting or mushrooming the head of hollow link pins. Riveting process is not required on solid link pin style master links with elongated U clip retainers.

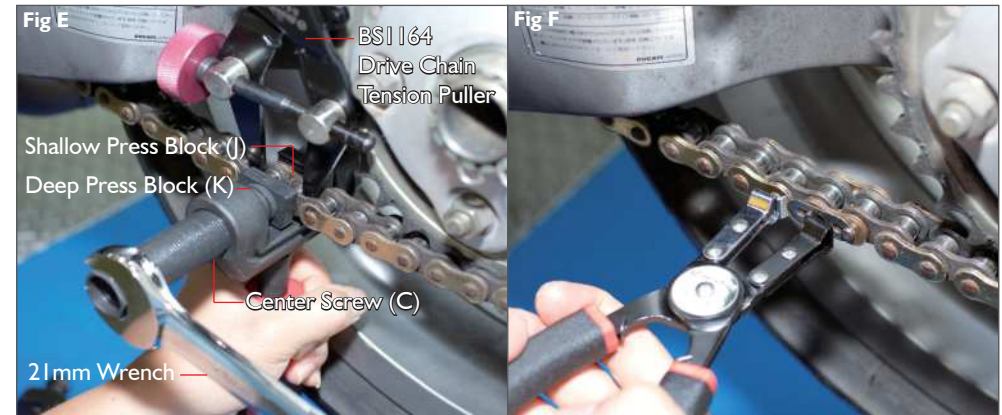

01. Check the chain manufacturer's instruction or workshop manual for installation.
02. Install the new chain over the pulley's sprockets and swing arm.
03. Use **BSI 164 Drive Chain Tension Puller** to fix the distance of Master Link
04. Using the new Master link grease the O-Rings and place these on the master link pins.
05. Join the chain using the master link from the back of the chain with the pins facing outwards. The rear sprocket will provide a position for the links to be joined easily.
06. Grease the Master link pins and install the O-Rings onto the hollow pins and then position the Master link backing plate. Greasing the backing plate will hold the plate in position prior to riveting. Note Ensure that the O-Rings are on the underside of the backing plate.
07. Using the Forcing Screw or 21 mm spanner tighten the Center Screw checking that the link is correctly aligned.
08. Compress the chain link until the chain Master link pins protrude above the Master link backing plate.
09. Ensure that the link is evenly compressed on both sides. This measurement can be easily checked with a vernier caliper. Refer to the chain manufacturers specification of recommended protrusion as this may vary depending on the brand of chain.
10. For Master Link U Clip design attach the U clip ensuring. Using **BS3506 Chain Link Pliers** to install that the U clip locks the backing plate firmly in position. (Fig F)

ASSEMBLY CHAIN PRESSING SIDE PLATES

Parts:

(H) Holding Tip x 2 pieces

(J) Shallow Press Block

(K) Deep Press Block

For All motorcycle chain size:

#415, #420, #428, #520, #525,

#530 (#50), #532 and #630, #632.

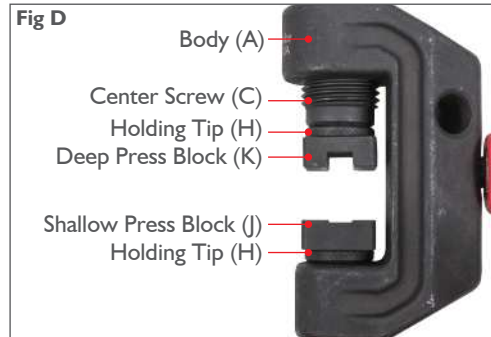

Assemble the tool as shown in (Fig D) for pressing side plates.

01. Thread the Center Screw into the Body of the tool.
02. 2 pieces Holding Tip (H) of the Center Screw and Body bottom, and lock them on screw thread at two sides.
03. Refer to (Fig D) as there are 2 pieces Press Block, Shallow (J) and Deep (K), and lock into the 2 sides Holding Tip (H) hole of the Center Screw and Body bottom.
04. The Shallow Press Block (J) is positioned base plate of the tool (fixed master link side) and the Deep Press Block (K) on the Center Screw side end of the tool with the Master link plate underneath.
(The installation direction depends on the chain link, Deep Press Block is distance of chain pin protrusion.)
05. This tool can be used to quickly remove the chain by conversely assembling the Shallow Press Block (J) on Center Screw and Deep Press Block (K) on the bottom of Body, and then repeating the Fig.E-Action.7.
(Different chains may require different operation.)

Chain assembly and riveting or mushrooming the head of hollow link pins. Riveting process is not required on solid link pin style master links with elongated U clip retainers.

Master Link Identification



Solid Pin U-Clip Master Link



Solid Pin U-Clip Master Link Assembled



Hollow Pin Rivet Master Link



Hollow Pin Rivet Master Link Assembled

The new type forged Body adopts three lock holes with different position and angle which allows a nimble application in varied space and angle when connecting the Handle.

Right and Left-Handed operation are both well-considered in this design and application which brings users the most ergonomically efficiency during operation.

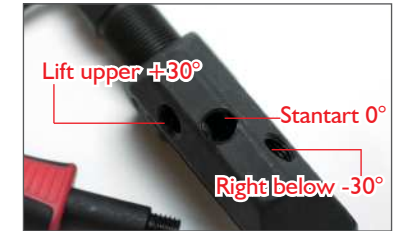

Handle hole positions.



Standard 0°

Lift upper +30°
(Easily applied in varied space and angle.)

Right below -30°
(Easily applied by left-handed user.)

Two pieces of special Holding Tip hold the chain in position firmly for chain breaking. When driving the Forcing Screw, this design can easily hold the Chain Pin in the central hole of the Holding Tip, efficiently locates and fixes the central point of Chain Pin, and accurately makes the Chain Pin positioned in right vertical angle. This assists the Chain Pin straying from the right angle or central position during the operation, and also, this design provides the user with more efficiency and convenience.



Holding the Chain Pin in central

BREAKING CHAINS

As chain sizes vary so do the pin sizes depending on the size of the chain links. The Tool breaking pins in the kit cover sizes to suit the following chain links.

- (F1) Small Holding Tip and (G1) Small Push Pin w/Spring, suits chains size #415, #420 and #428.
- (F2) Medium Holding Tip and (G2) Medium Push Pin w/Spring, suits chains size #520, #525, #530 (#50) and #532.
- (F3) Large Holding Tip and (G3) Large Push Pin w/Spring, suits chains size #630 and #632.
- (H) Holding Tip for all chains.

(Fig A) Details the correct assembly of the Tool for breaking the Chain Pin.

Assembly of the Tool

01. Screw the Center Screw into the Tool Body.
02. According to the size of chain, choose corresponding Holding Tip (F) for the Center Screw and Holding Tip (H) for the Body bottom. and lock them on the screw threaded body two sides.
03. Select the correct size Push Pin, with spring according to the chain size and assemble. Then insert the Push Pin into the centre of the Center Screw.
04. Screw the Forcing Screw or T-Bar into the Center Screw to hold in position.

Make sure the Push Pin is well operated into the centre of the Holding Tip (F) during the operation. Ensure that the Push Pin is retracted from the nosepiece, prior to preparing the operation.

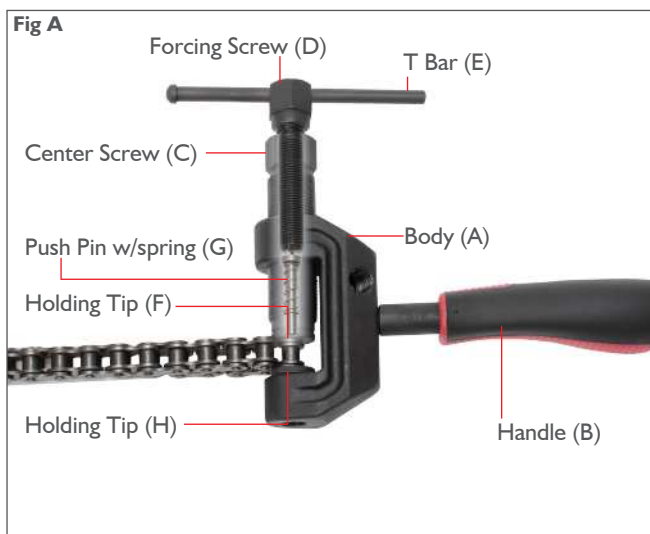

(Fig B) Details the position of the Chain to pressing the chain link pin out.



01. Find out the fixed point of the Chain Link, and use **BS3506 Chain Link Pliers** for removal of U clip-type master chain link. **(Fig C)**.
02. Ensure the Chain is positioned straight with the Chain Pin head over the hole in the Body of the tool. To assist in the pin pressing operation grind flat the mushroomed head of the chain link pin. Ensure the pressing pin is aligned.
03. Twisting of the Tool or misalignment could cause damage to the tool and the Push Pin. Place the Chain Pin exactly between the hole of two sides of Holding Tip (F and H in Fig A). Adjust the Center Screw to fix the Chain Link. The underside of the link pin should be aligned over the hole in the tool Body to allow the chain link pin to be pressed into the hole.
04. Using the T-Bar or a 19mm spanner, turn the Forcing Screw the Push Pin to push the Chain Pin out of the chain link.
05. Repeat the **Operation 3**. to push the other pin out from the Chain Link to complete the chain breaking.

CAUTION

Should the chain link pin not press out do not use excessive force as this may damage the tool. Check the tool for alignment, disassemble the tool if necessary and reassemble, align and commence the operation as detailed above.